

MODEL: SF-32;SF-33

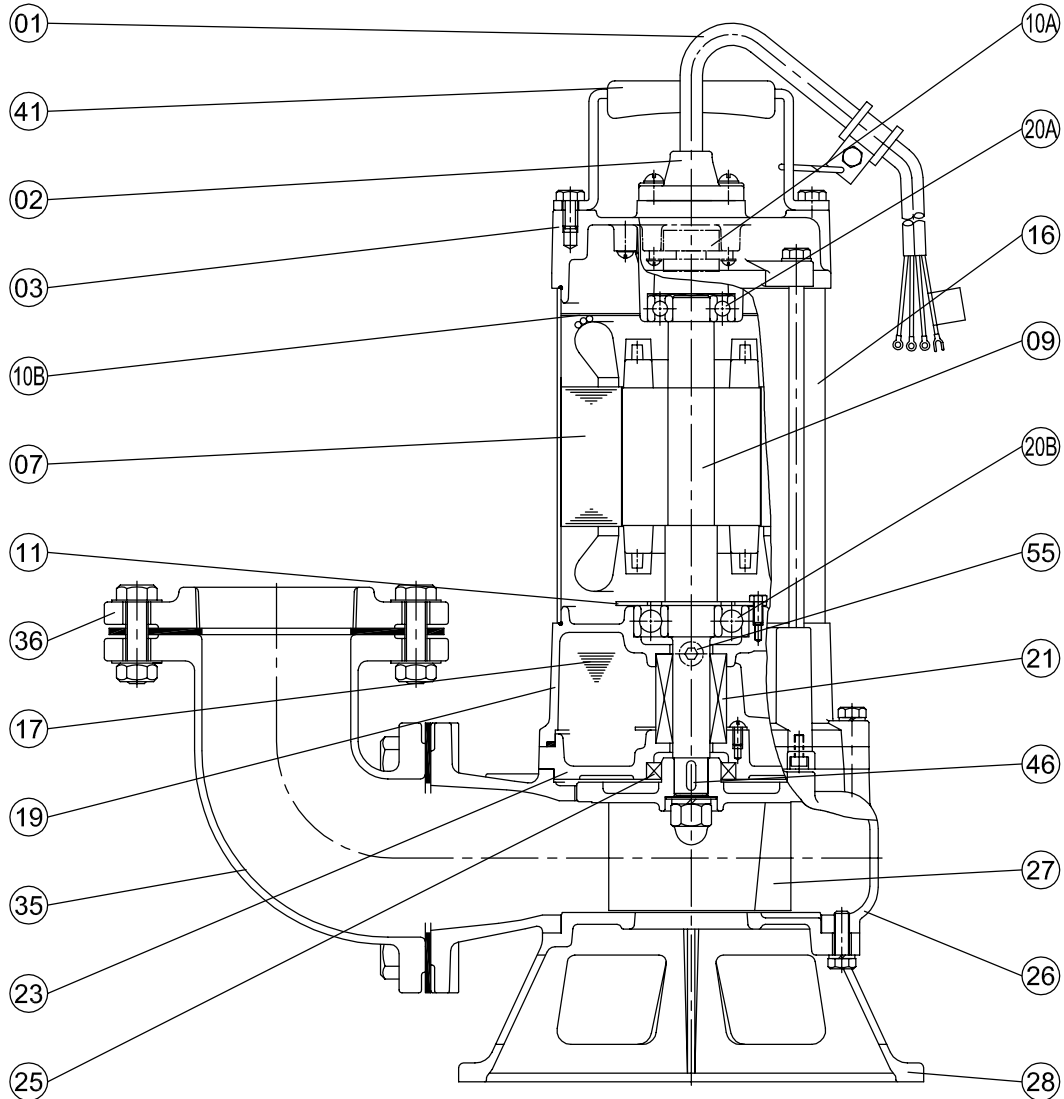

No.	Part name	Material	QTY	Remark
01	Cable	VCT	1	
02	Cable base	SUS316	1	
03	Upper cover	SUS316	1	
07	Stator		1	
09	Shaft(with Rotor)	SUS316	1	
10A	Auto-cut		1	
10B	Auto-cut plate		1	
11	Bearing fixer	SS41	1	
16	Motor frame	SUS316	1	
17	Lubricant	Turbine oil #32	1	
19	Bearing bracket	SCS14	1	
20A	Upper bearing		1	
20B	Lower bearing		1	
21	M. seal	CA VS CE SIC VS SIC	1	

No.	Part name	Material	QTY	Remark
23	M. seal bracket	SUS316	1	
25	Oil seal	NBR	1	
26	Casing	SUS316	1	
27	Impeller	SUS316	1	
28	Casing cover	SUS316	1	
35	Coupling	SUS316	1	
36	Flange	SUS316	1	
41	Handle	SUS304	1	
46	Impeller key	SUS304	1	
47	Packing (1 set)		1	
55	Oil plug	SUS304	1	