

MODEL: AF-1450;AF-1460;AF-1650;AF-1660

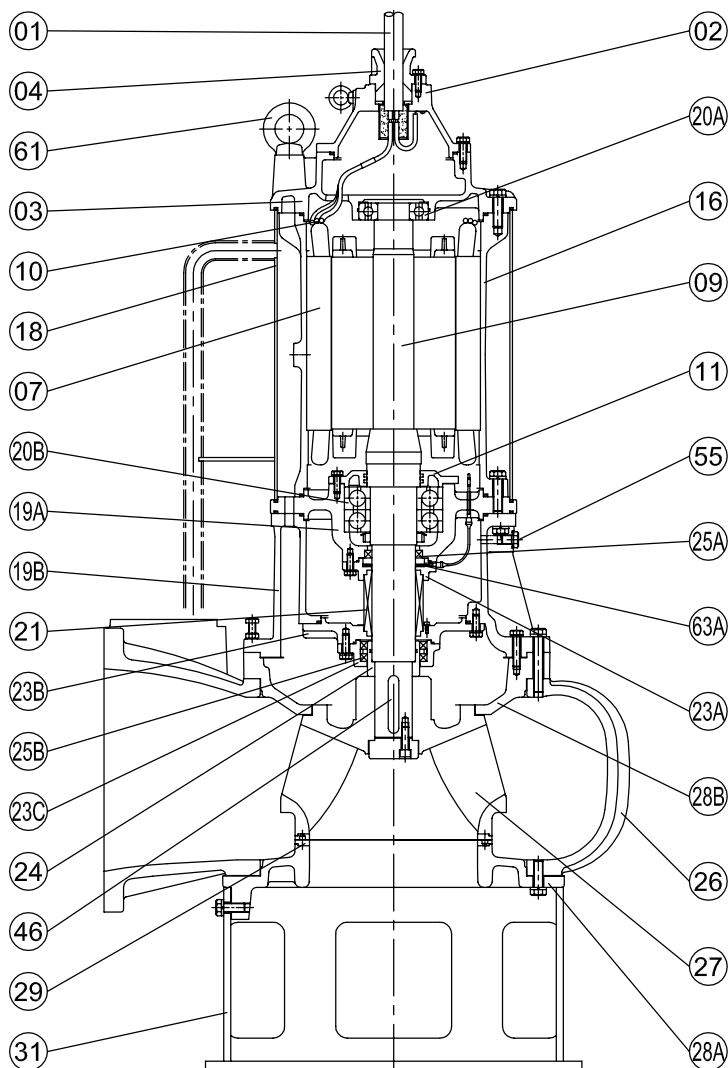

No.	Part name	Material	QTY	Remark
01	Cable	3PNCT	1	
02	Cable base	FC-200	1	
03	Upper cover	FC-200	1	
04	Cable base cover	FC-200	1	
07	Stator		1	
09	Shaft(with Rotor)	SUS420J2	1	
10	Auto-cut		3	
11	Bearing fixer	FC-200	1	
16	Motor frame	FC-200	1	
17	Lubricant	Turbine oil #32	1	
18	Out cover	SS41	1	
19A	Bearing bracket	FC-200	1	
19B	Oil chamber	FC-200	1	
20A	Upper bearing		1	
20B	Lower bearing		1	
21	M. seal	SIC VS SIC	1	
23A	Upper M. seal bracket	FC-200	1	

No.	Part name	Material	QTY	Remark
23B	Lower M. seal bracket	FC-200	1	
23C	Oil seal bracket	FC-200	1	
24	Oil seal bush	SUS420J2	1	
25A	Oil seal (S C)	NBR	1	
25B	Oil seal	NBR	2	
26	Casing	FC-200	1	
27	Impeller	FC-200	1	
28A	Casing cover	FC-200	1	
28B	Upper Casing cover	FC-200	1	
29	Impeller bush	SUS304	2	
31	Strainer	SS41	1	
46	Impeller key	SUS304	1	
47	Packing (1 set)		1	
55	Oil plug	SUS304	1	
61	S.T. chain (Eye bolt)	SUS304	3	
63	M. seal water detector		2	