

MODEL: A-32T;A-33 1Ø

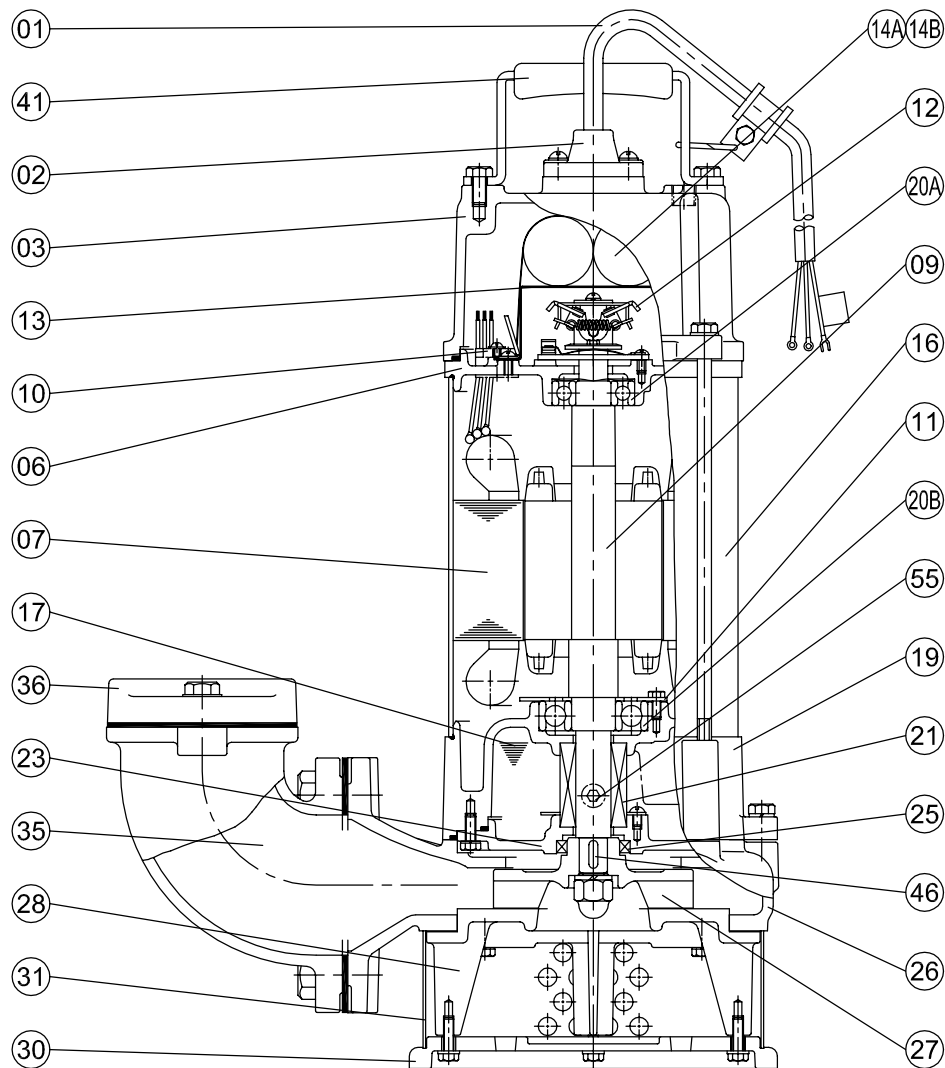

No.	Part name	Material	QTY	Remark
01	Cable	VCT	1	
02	Cable base	PC+PBT	1	
03	Upper cover	FC-200	1	
06	Bracket	FC-200	1	
07	Stator		1	
09	Shaft(with Rotor)	SUS403	1	
10	Auto-cut		1	*
11	Bearing fixer	SS41	1	
12	Centrifugal switch		1	
13	Centrifugal switch cover		1	
14A	Capacitor		1	
14B	Start capacitor		1	
16	Motor frame	SUS304	1	
17	Lubricant	Turbine oil #32	1	
19	Bearing bracket	FC-200	1	
20A	Upper bearing		1	

No.	Part name	Material	QTY	Remark
20B	Lower bearing		1	
21	M. seal	CA VS CE	1	
23	M. seal bracket	FC-200	1	
25	Oil seal	NBR	1	
26	Casing	FC-200	1	
27	Impeller	FC-200	1	
28	Casing cover	FC-200	1	
30	Footing	FC-200	1	
31	Strainer	SUS304	1	
35	Coupling	FC-200	1	
36	Flange	FC-200	1	
41	Handle	SS41	1	
46	Impeller key	SUS304	1	
47	Packing (1 set)		1	
55	Oil plug	SUS304	1	

*Auto-cut for A-33 1Ø is unobtainable now.